



TRENDY

mod. A

mod. B

mod. C



CARBONI ALDO TECHNOLOGY SRL

TRENDY TRENDY TRENDY TRENDY TRENDY
TRENDY TRENDY TRENDY TRENDY TRENDY
TRENDY TRENDY TRENDY TRENDY TRENDY
TRENDY TRENDY TRENDY TRENDY TRENDY
TRENDY TRENDY TRENDY TRENDY TRENDY
TRENDY TRENDY TRENDY TRENDY TRENDY
TRENDY TRENDY TRENDY TRENDY TRENDY
TRENDY TRENDY TRENDY TRENDY TRENDY
TRENDY TRENDY TRENDY TRENDY TRENDY
TRENDY TRENDY TRENDY TRENDY TRENDY
TRENDY TRENDY TRENDY TRENDY TRENDY
TRENDY TRENDY TRENDY TRENDY TRENDY
TRENDY TRENDY TRENDY TRENDY TRENDY
TRENDY TRENDY TRENDY TRENDY TRENDY
TRENDY TRENDY TRENDY TRENDY TRENDY
TRENDY TRENDY TRENDY TRENDY TRENDY

26010 Azzanello (CR) • Italy • Via Madonnina della Breda 1
Tel. 0374.661211 • Fax 0374.661234
www.carbonialdo.com • e-mail: info@carbonialdo.com

Pompa oleodinamica verticale con freno
Vertical oleodynamic pump with brake

Trendy 170

- ▶ Con freno meccanico per bloccaggio stelo pompa per antirotazione poltrona
- ▶ Fissaggio della pompa su base con sede conica femmina

SPECIFICHE tecniche

Corsa massima stelo : 170 mm.
Forza di spinta dinamica : 300 daN. a 60 Bar
Carico statico massimo : 400 daN. a 80 Bar
Rapporto carico stelo/carico sul pedale : ... 8.5 / 1
Velocità di ritorno : 22 ÷ 28 mm/sec.
(con carico di 102 daN.)
N° azionamenti pedale : 26 ÷ 29
(corsa 170 mm.)
Peso : 7 Kg. (7.15 daN)

- ▶ With mechanical brake for clamping rod pump (for anti-rotating armchair)
- ▶ Pump attachment on base with female conical seat

Technical SPECIFICATIONS

Push rod max. stroke : 170 mm.
Push force (dynamic) : 300 daN. at 60 Bar
Maximum static load : 400 daN. at 80 Bar
Rod load / pedal load ratio : 8.5 / 1
Rod return speed : 22 ÷ 28 mm/sec.
(with 102 daN. load)
Nr. of pumpstrokes : 26 ÷ 29
(170 mm. stroke)
Weight : 7 Kg. (7.15 daN)

Come ordinare - How to order

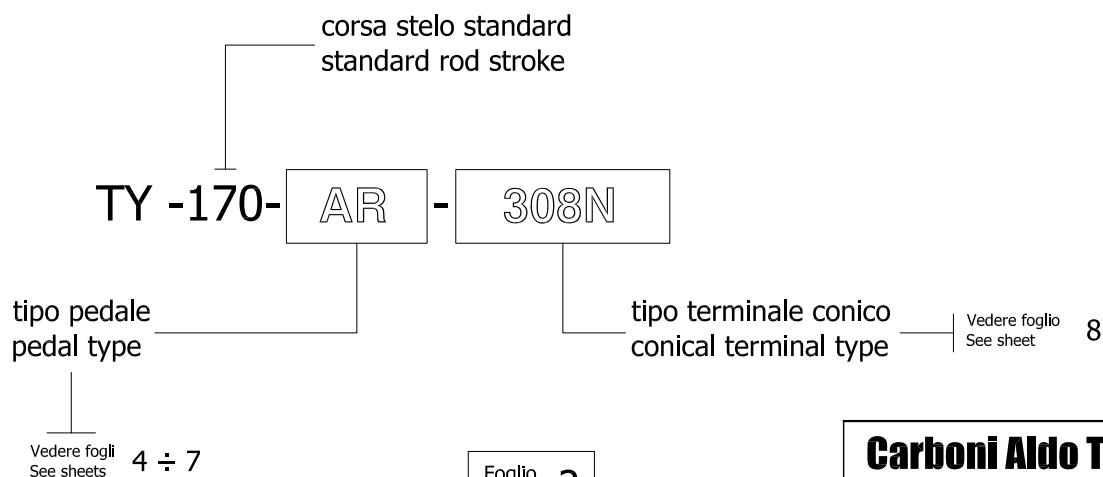

Carboni Aldo Technology

AZZANELLO (Cremona-Italy)

Pompa oleodinamica verticale con freno
Vertical oleodynamic pump with brake

Trendy 170

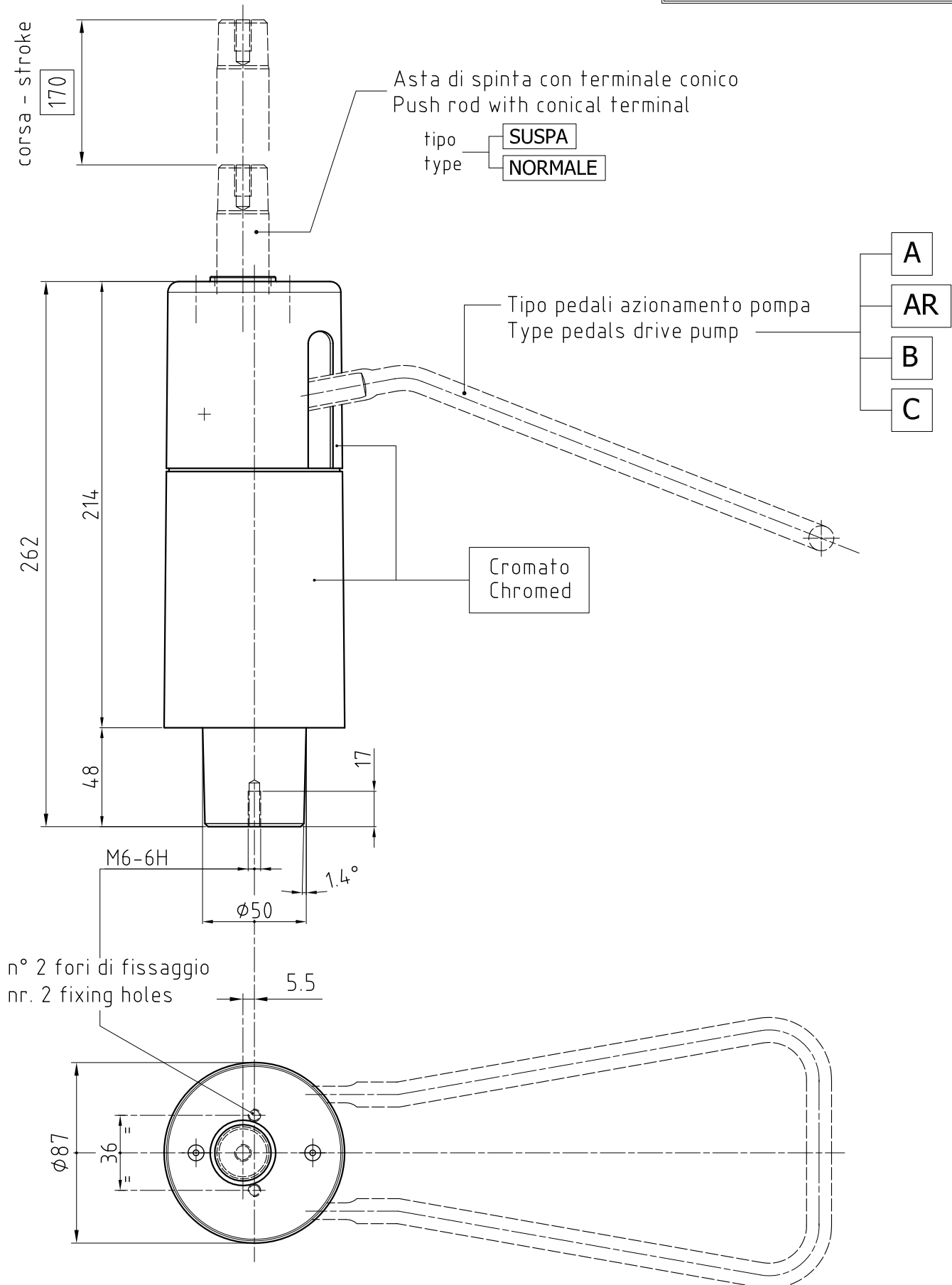

Pompa oleodinamica verticale con freno
Vertical oleodynamic pump with brake

Trendy 170

Dettaglio PEDALE azionamento pompa
PEDAL drive pump detail

tipo
type

A

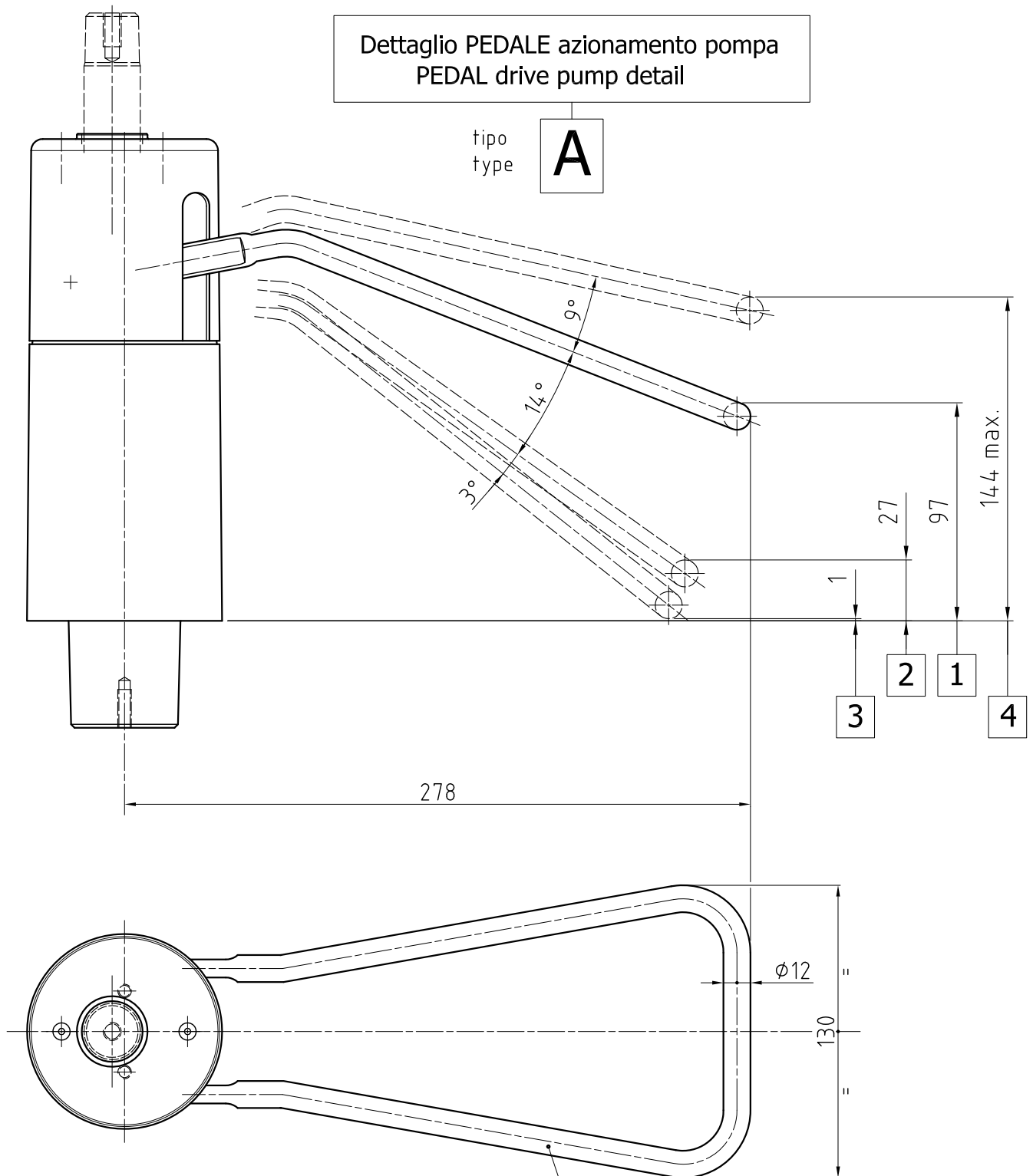

- 1** — Posizione pedale a riposo
Pedal in rest position
- 2** — Azionamento corsa stelo
Rod stroke operation
- 3** — Azionamento rientro stelo
Rod return operation
- 4** — Azionamento freno
Brake operation

Cromato
Chromed

Pompa oleodinamica verticale con freno
Vertical oleodynamic pump with brake

Trendy 170

Dettaglio PEDALE azionamento pompa
PEDAL drive pump detail

tipo
type

AR

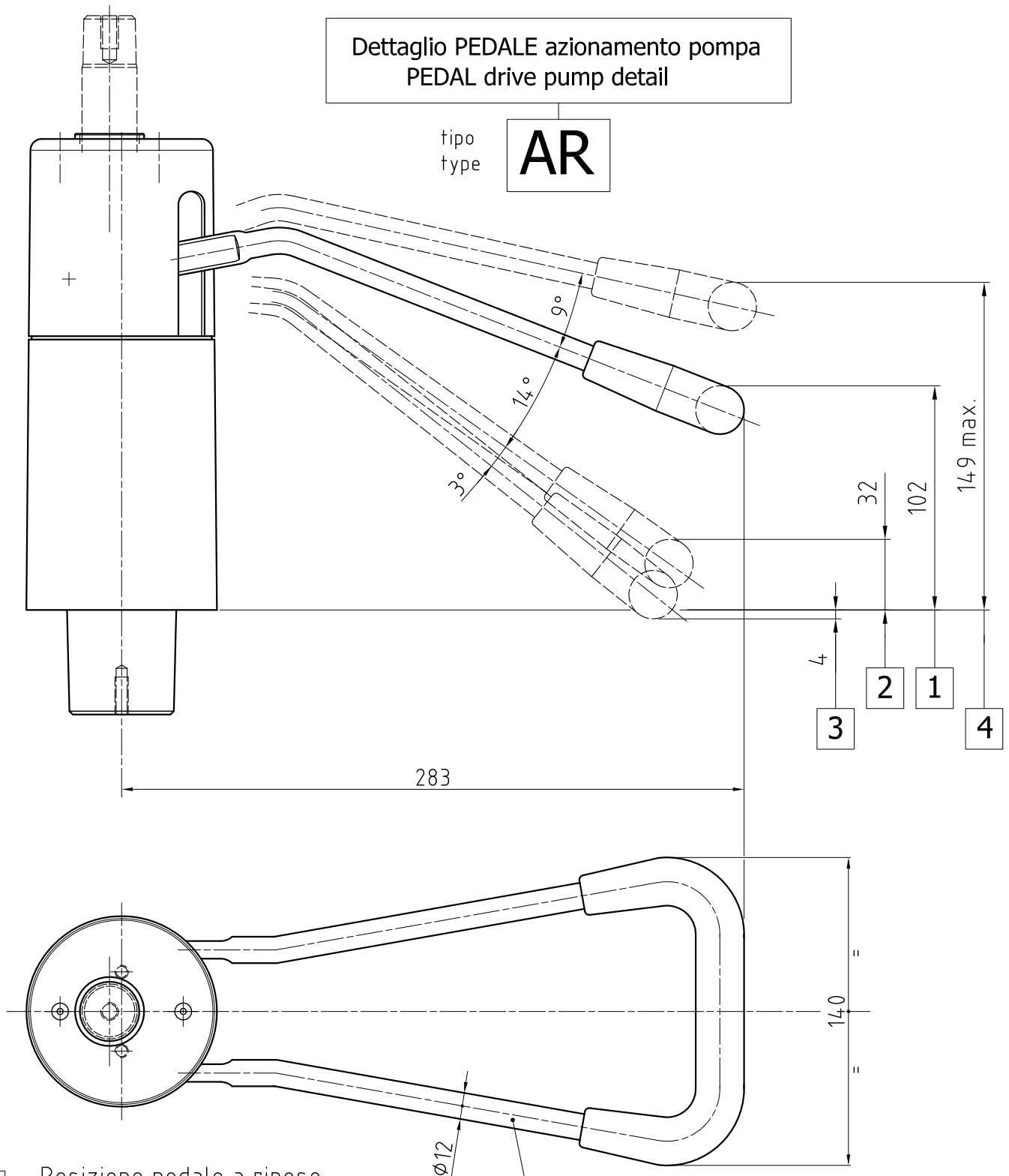

- 1 Posizione pedale a riposo
Pedal in rest position
- 2 Azionamento corsa stelo
Rod stroke operation
- 3 Azionamento rientro stelo
Rod return operation
- 4 Azionamento freno
Brake operation

Pedale cromato con rivestimento
in poliuretano nero
Chromed pedal with polyurethane
covering (black)

Pompa oleodinamica verticale con freno
Vertical oleodynamic pump with brake

Trendy 170

Dettaglio PEDALE azionamento pompa
PEDAL drive pump detail

tipo
type

B

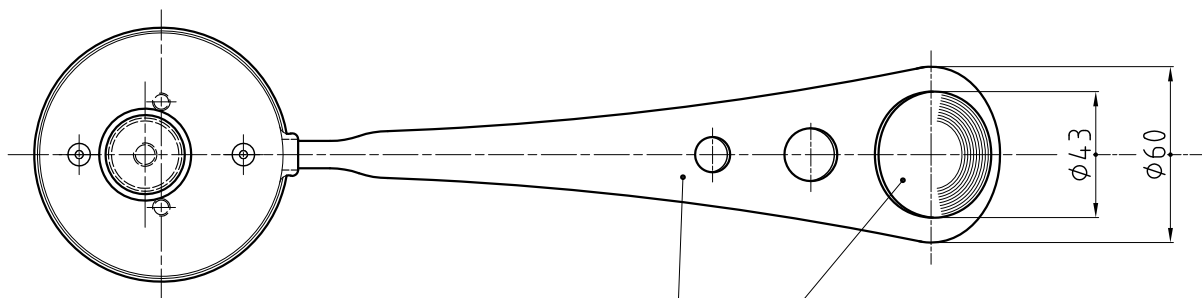
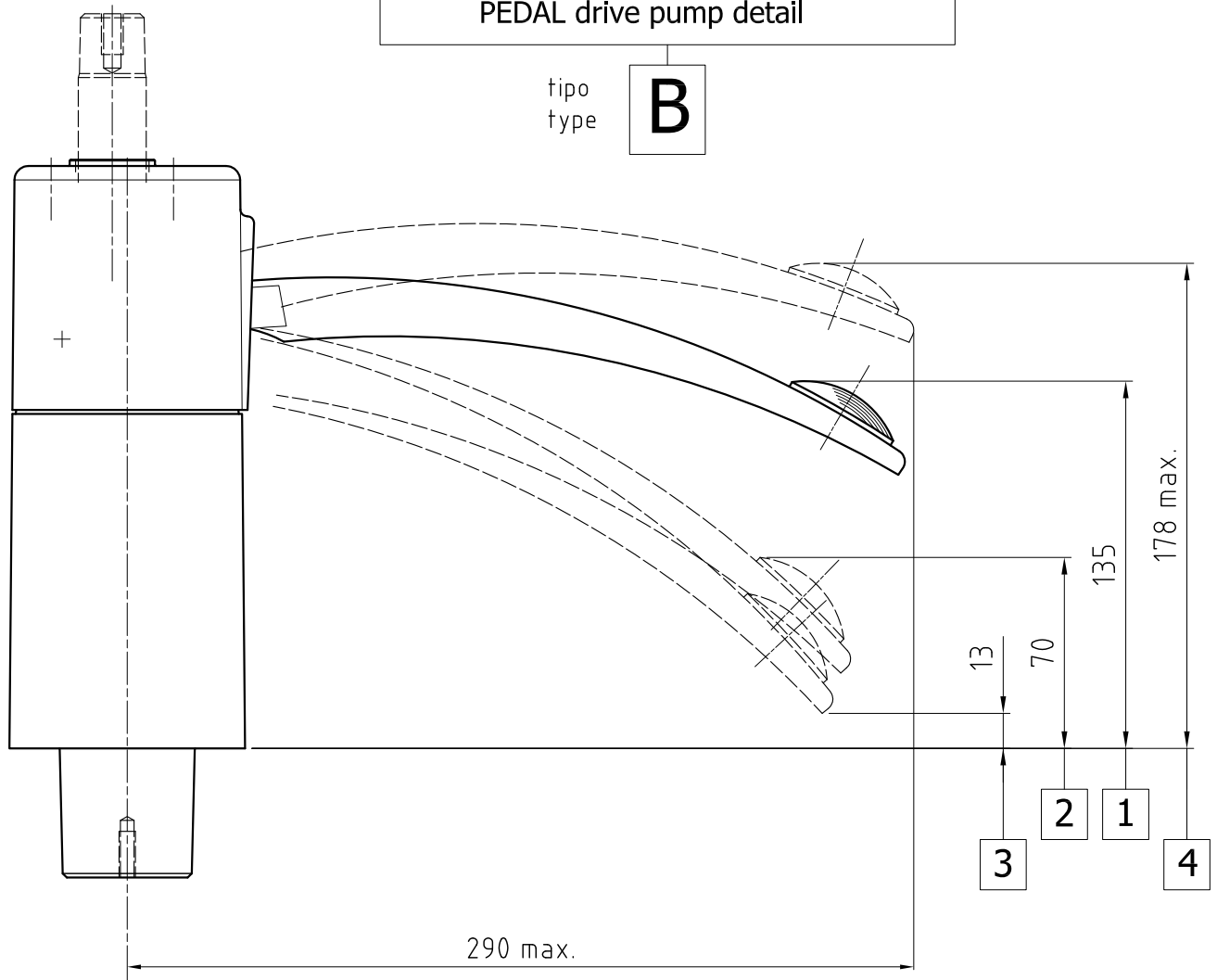

- 1 Posizione pedale a riposo
Pedal in rest position
- 2 Azionamento corsa stelo
Rod stroke operation
- 3 Azionamento rientro stelo
Rod return operation
- 4 Azionamento freno
Brake operation

Pedale cromato con inserto
in gomma nera
Chromed pedal with rubber
insert (black)

Pompa oleodinamica verticale con freno
Vertical oleodynamic pump with brake

Trendy 170

Dettaglio PEDALE azionamento pompa
PEDAL drive pump detail

tipo
type

C

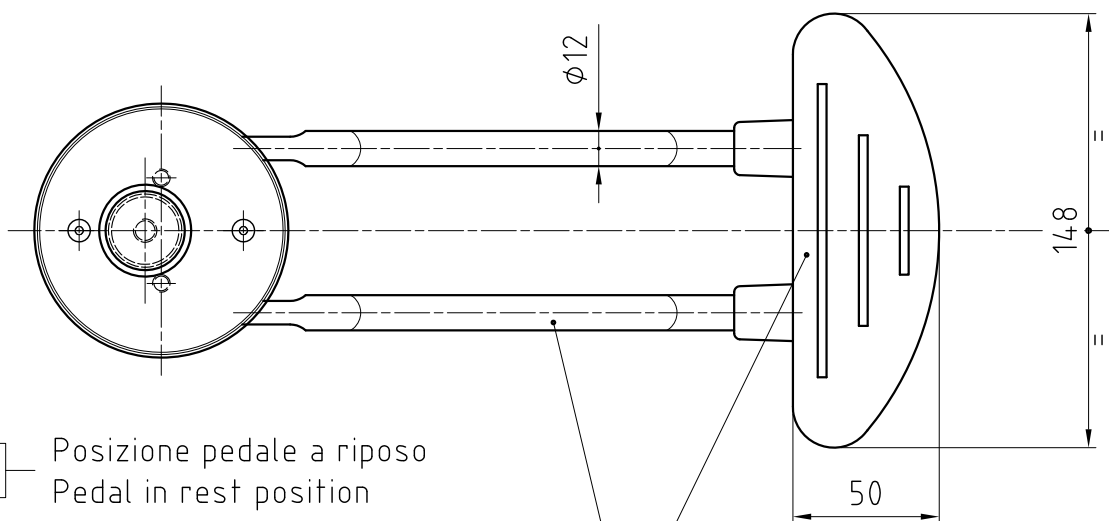
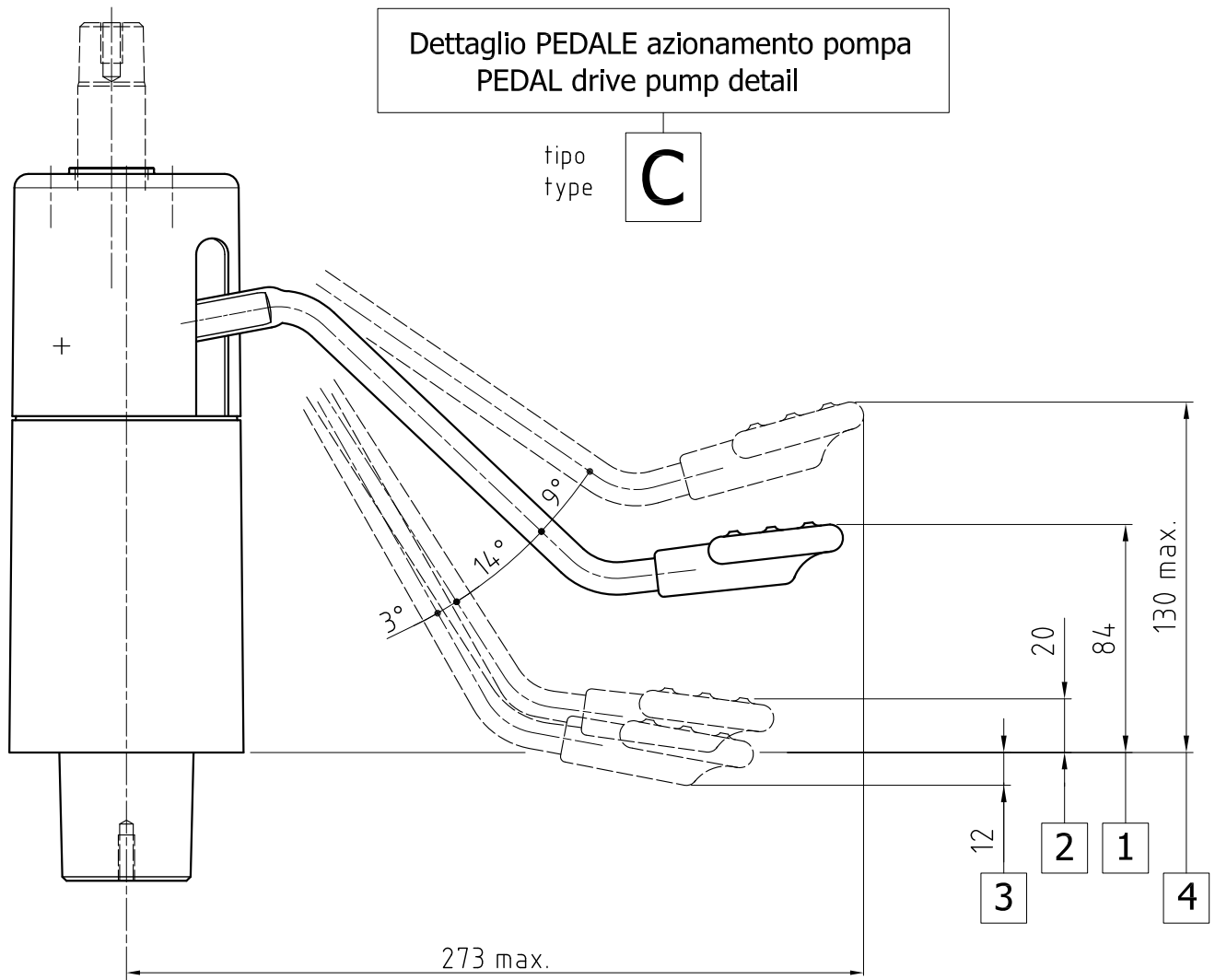

- 1** — Posizione pedale a riposo
Pedal in rest position
- 2** — Azionamento corsa stelo
Rod stroke operation
- 3** — Azionamento rientro stelo
Rod return operation
- 4** — Azionamento freno
Brake operation

Pedale cromato con rivestimento
in poliuretano nero
Chromed pedal with polyurethane
covering (black)

Pompa oleodinamica verticale con freno
Vertical oleodynamic pump with brake

Trendy 170

TERMINALI CONICI per piastre fissaggio poltrona
CONICAL TERMINALS for mounting seat plates

Cono tipo SUSPA
SUSPA cone type

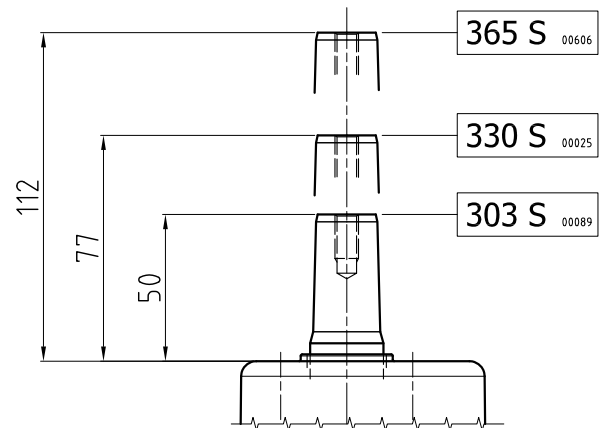
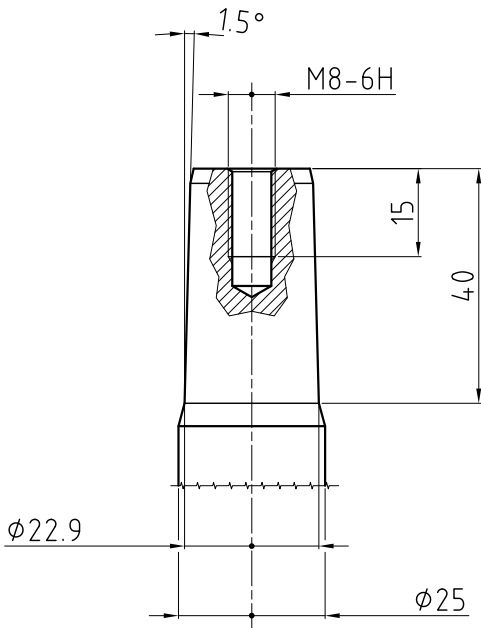

Cono tipo NORMALE
NORMAL cone type

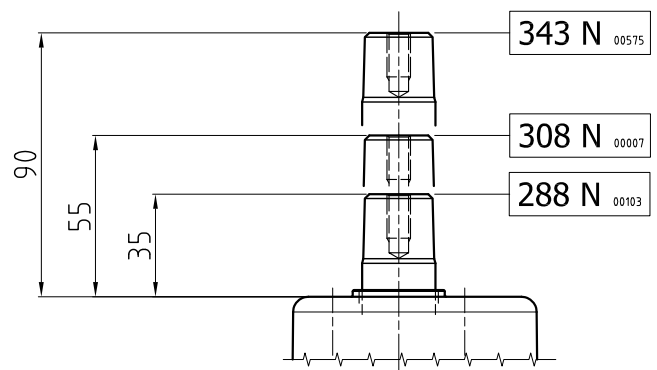
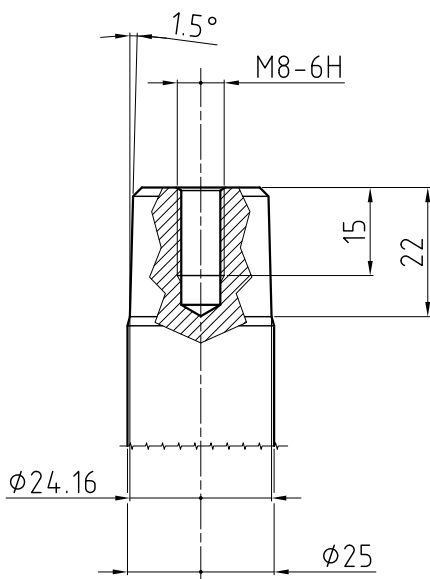

Pompa oleodinamica verticale con freno
Vertical oleodynamic pump with brake

Trendy 170

Dettaglio cono di fissaggio alla base
Base fixing cone detail

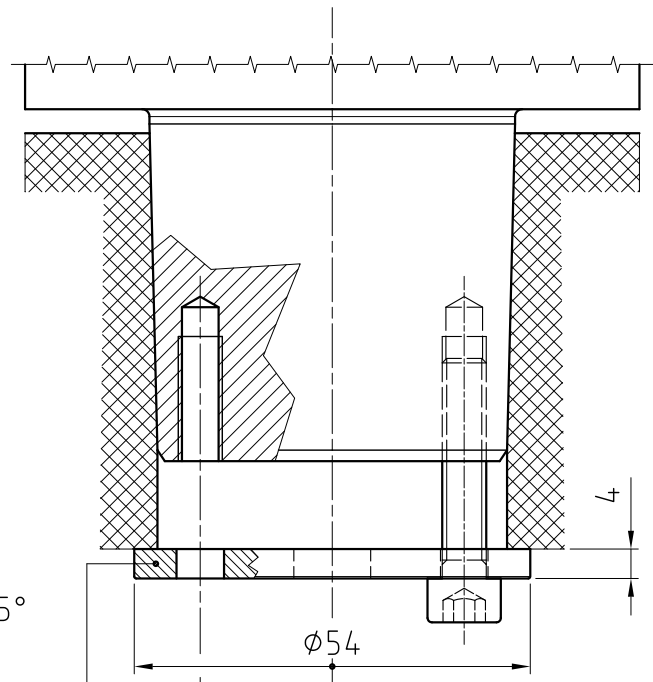
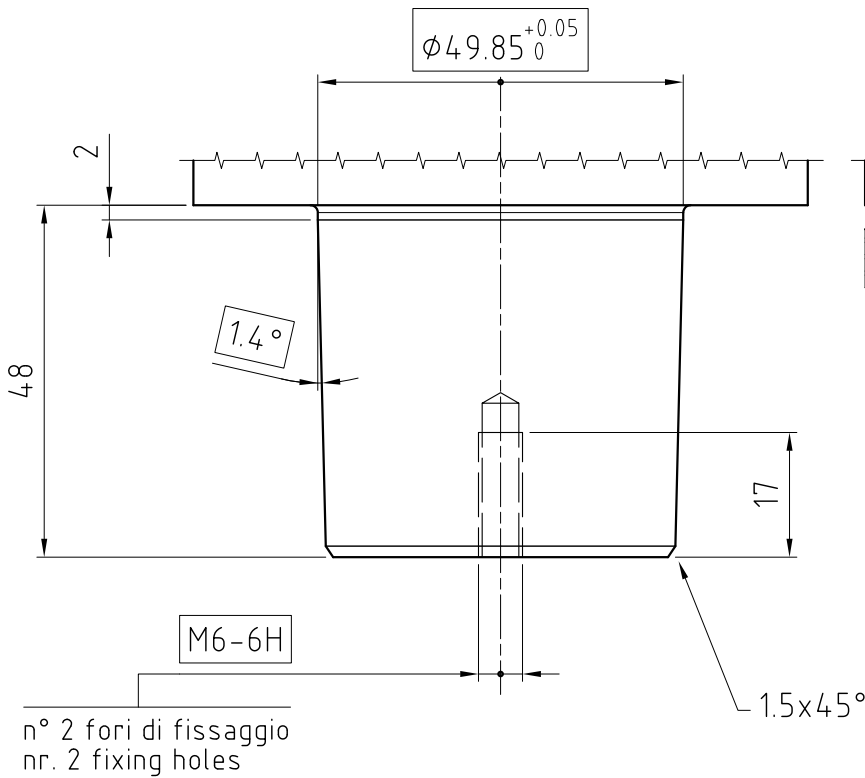
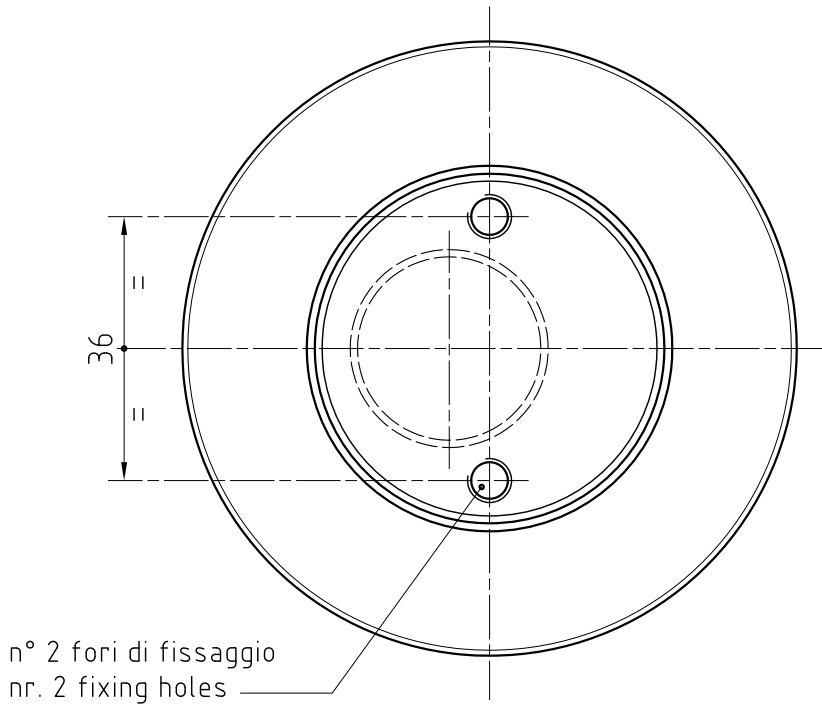

RONDELLA di appoggio
(fornita su richiesta)
Support WASHER
(supplied on request)



n° 2 viti M6 (non fornite)
nr. 2 screws M6 (not supplied)